

LOC		DIST		REVISIONS			
AD	00	P	LTR	DESCRIPTION	DATE	BY	APVD
		A		063C-0756-04	23FEB2006	RB	DR

- 1 HOUSING & ORGANIZER MATERIAL; UL94 V-0 RATED LCP, COLOR: NATURAL.
CONTACT MATERIAL; PHOS BRONZE
BOARDLOCK MATERIAL; BRASS
- 2 CONTACT PLATING; 0.76 μm MIN GOLD IN MATING AREA
2.54 μm - 5.08 μm MATTE TIN LEAD IN SOLDER AREA.
BOTH OVER 1.27 μm MIN NICKEL ON ENTIRE STOCK.
- 3 BOARDLOCK PLATING; 3.8 μm MIN BRIGHT TIN/LEAD ON ENTIRE STOCK
OVER 1.27 μm MIN NICKEL ON ENTIRE STOCK.
- 4 DATUM ESTABLISHED BY CUSTOMER.
- 5 BASIC DIMENSIONS ESTABLISHED BY CUSTOMER.
- 6 THIS PRODUCT HAS NOT COMPLETED VALIDATION TESTING.
- 7 NO TRACES ON EXTERNAL BOARD LAYER IN THIS AREA. KEEPOUT.
- 8 NO SOLDER PASTE PERMITTED ON THESE PADS.
- 9 CONTACT PLATING; 0.76 μm MIN GOLD IN MATING AREA
2.54 μm - 5.08 μm TIN IN SOLDER AREA.
BOTH OVER 1.27 μm MIN NICKEL ON ENTIRE STOCK.
- 10 BOARDLOCK PLATING; 3.8 μm MIN TIN ON ENTIRE STOCK
OVER 1.27 μm MIN NICKEL ON ENTIRE STOCK.
- 11 ROHS 2002/95/EC COMPLIANT.

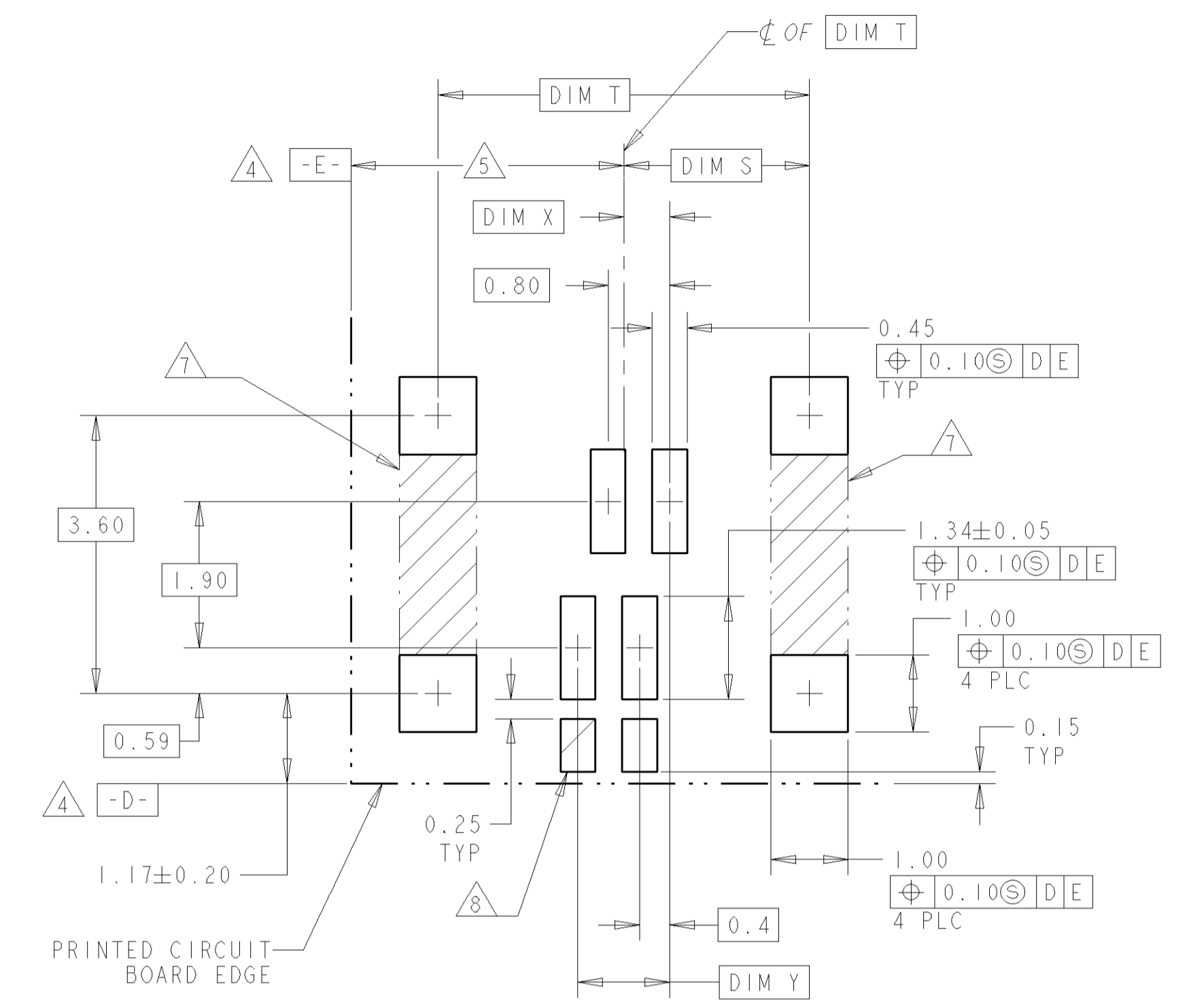
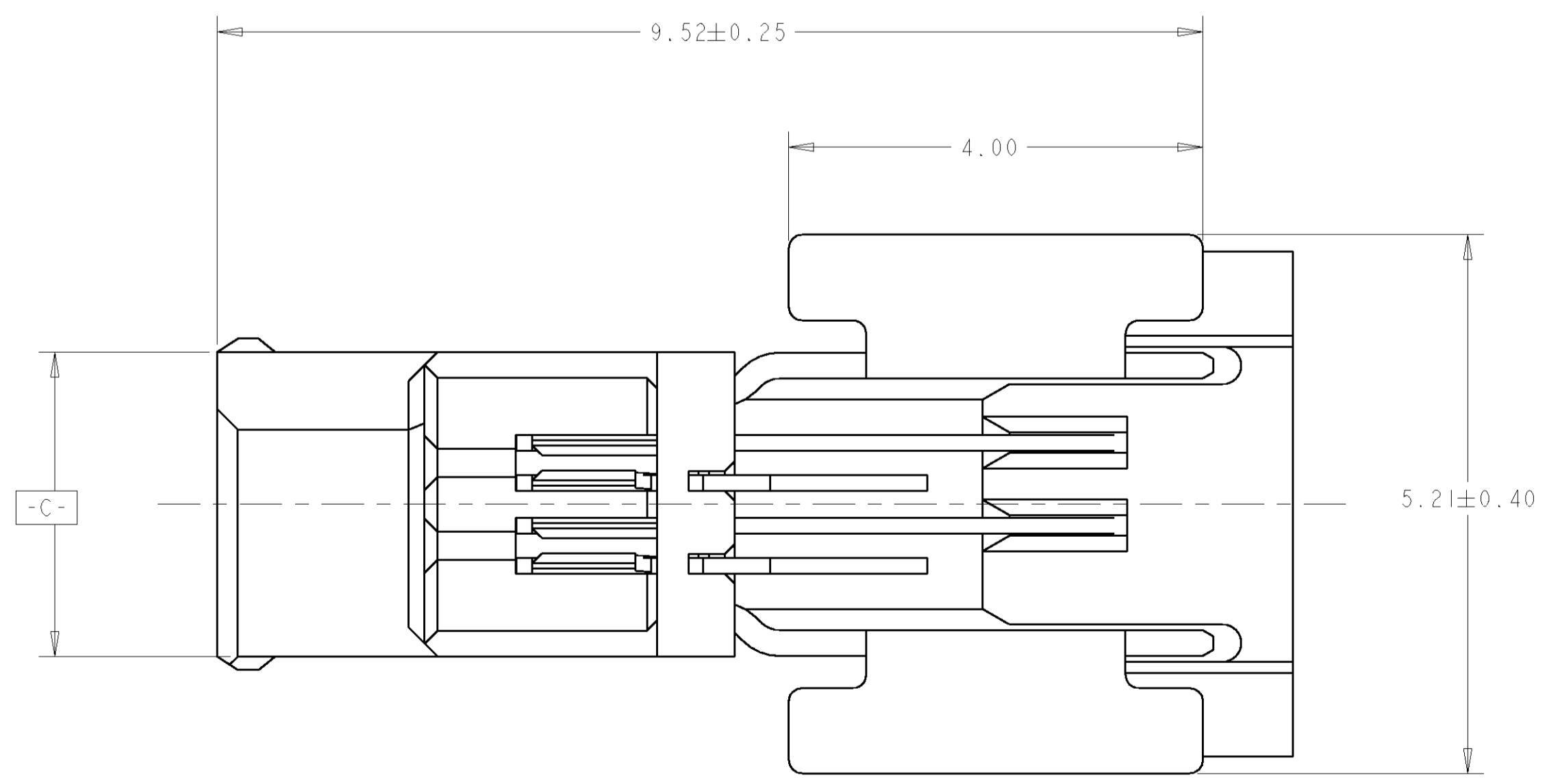
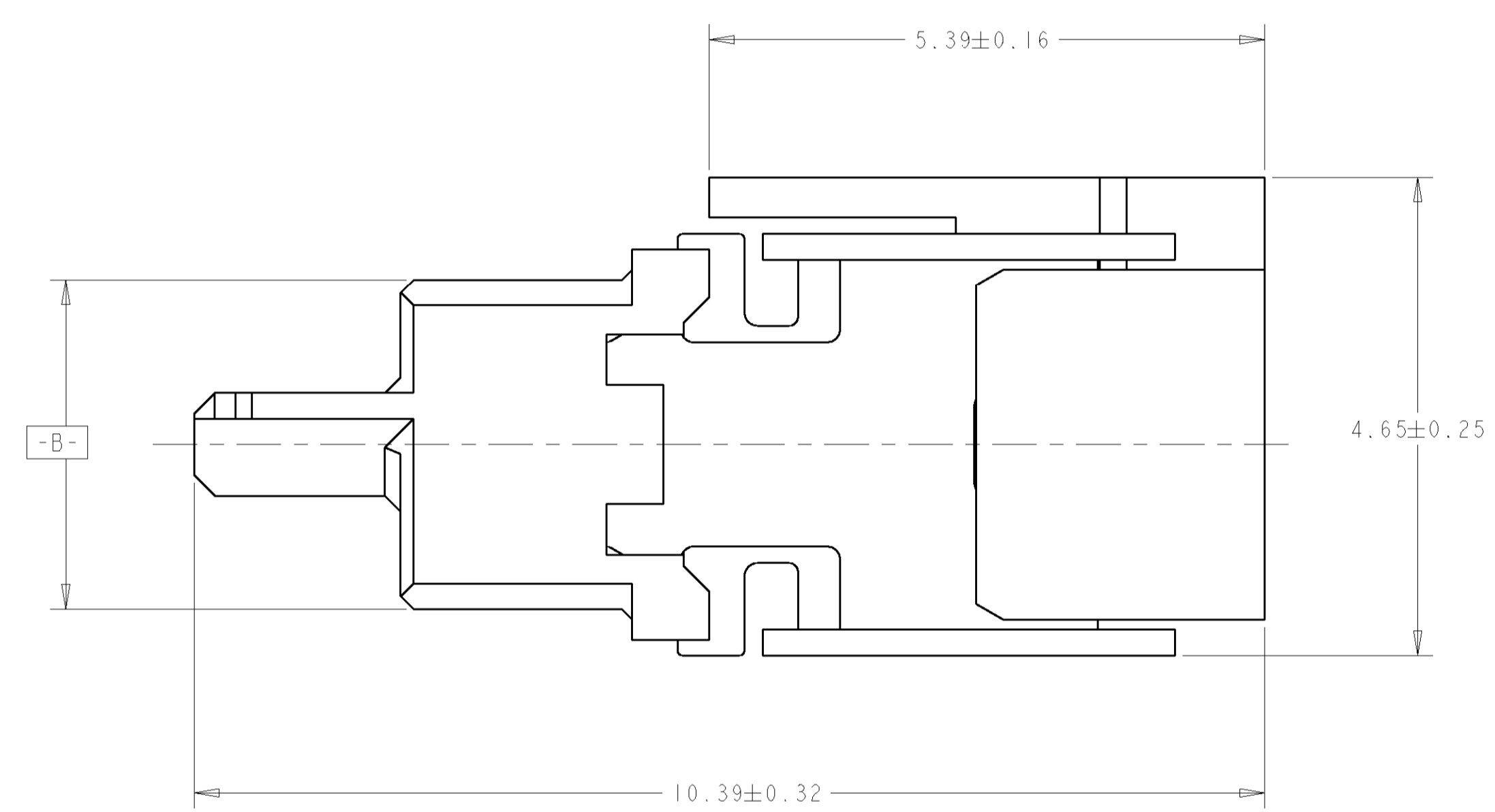
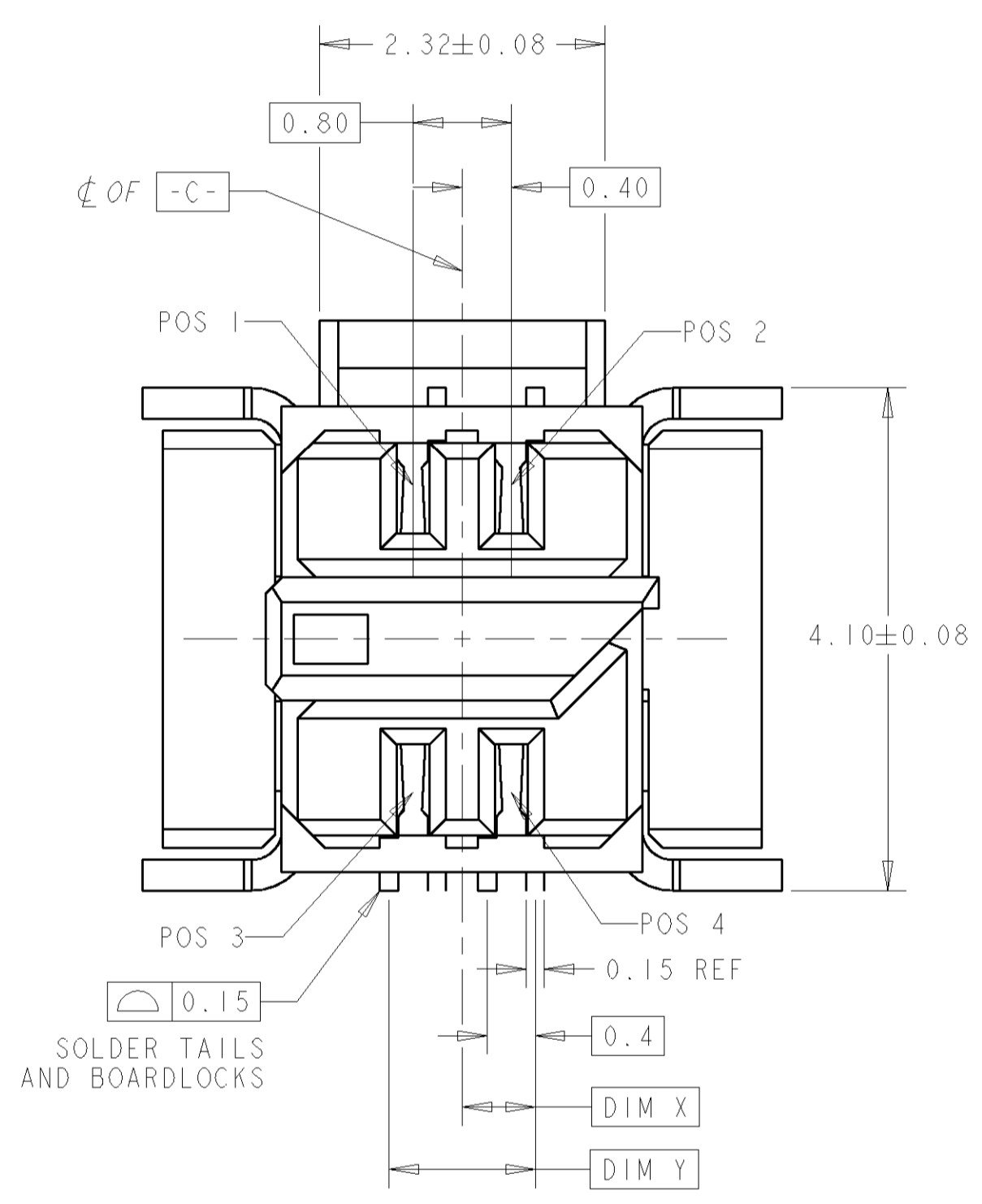

PC BOARD LAYOUT
SCALE 15:1

1	10	9	1.20	0.60	4.82	2.41	4	5-1445940-1
3	2		1.20	0.60	4.82	2.41	4	1445940-1
			DIM Y	DIM X	DIM T	DIM S	NO. OF POS	PART NUMBER

DIMENSIONS: mm 		TOLERANCES UNLESS OTHERWISE SPECIFIED: 0 PLC ± 1 PLC ±0.2 2 PLC ±0.08 3 PLC ± 4 PLC ± ANGLES ±1°		DWN R. L. KOLLER 09NOV2001 ENR L. BREKOSKY 12NOV2001 APVD -		Tyco Electronics Harrisburg, PA 17105-3608	
MATERIAL		FINISH		NAME		PRODUCT SPEC	
SEE TABLE				AMPMODU MICRO INTERCONNECT RECEPTACLE ASSEMBLY, RIGHT ANGLE		APPLICATION SPEC	
				SIZE CAGE CODE DRAWING NO		RESTRICTED TO	
				A 00779 C=1445940			
				CUSTOMER DRAWING		SCALE 20:1 SHEET 1 OF 1 REV A	